

Limited Warranty

Duration of the Warranty

This warranty will remain in effect for one (1) year from the date of original purchase.

Who May Enforce the Warranty

This warranty may be enforced by the original purchaser and subsequent owners during the warranty period, so long as the original dated sales receipt or other proof of warranty coverage is presented when warranty service is required.

What is Covered and What is Not Covered

Except as specified below, this warranty covers all defects in material and workmanship in this product. The following are not covered by the warranty:

1. Damage resulting from:
 - A. Accident, misuse, abuse, or neglect.
 - B. Failure to follow instructions contained in your Owner's Manual.
 - C. Repair or attempted repair by anyone not authorized by RTI.
 - D. Failure to perform recommended periodic maintenance.
 - E. Causes other than product defects, including lack of skill, competence, or experience of user.
2. Damage occurring during any shipment of this product (claims must be presented to the carrier).
3. Damage to any unit which has been altered or on which the serial number has been defaced, modified, or removed.

What We Will Pay For

We will pay all labor and material expenses for covered items. Payment of shipping charges is discussed in the next section of this warranty.

How You Can Get Service

If your unit needs service, please write, E-mail or telephone us and we will advise you where the unit should be taken or sent. If you write or E-mail us, include your name, complete address, daytime telephone number and a description of the problem(s). *Please do not return your unit to the factory without our prior authorization.*

If it is necessary to ship the product for service:

- A. You must pay for any initial shipping charges, but if the necessary repairs are covered by the warranty, we will pay the return shipping charges via a carrier of our choice to any destination within the United States.
 - B. The unit should be packed securely, and we suggest that it be insured.
- Whenever warranty service is required, a copy of the original dated sales receipt must be presented.

Limitation of Implied Warranties

Any implied warranties, *including warranties of merchantability and fitness for a particular purpose*, are limited in duration to the length of this warranty.

Exclusion of Certain Damages

RTI's liability for any defective product is limited to repair or replacement of the product, at our option, RTI shall not be liable for:

1. Damages based upon inconvenience, loss of use of the product, loss of time, interrupted operation, commercial loss; *or*
2. Any damages, whether incidental, consequential, or otherwise.

How State Law Relates to the Warranty

Some states do not allow limitation on how long an implied warranty lasts and/or do not allow the exclusion or limitations of incidental or consequential damages, so the above limitations may not apply to you.

This warranty is not enforceable outside of North America. This warranty gives you specific rights, and you may also have other rights which vary from state to state.

Specifications

Compatible with industry standard IR emitters (Xantech® or compatible).

IR Output Drive ~ 100mA maximum

Input Requirements ~ NTSC, PAL or SECAM Composite Video

Unit Dimensions ~ 1.75" wide x 3.0" long x 0.70" thick

SPS-1 Video Sync Power Sensor Installation & Operation Guide



www.rticorp.com

Introduction

The SPS-1 Video Sync Power Sensor is a device that monitors the on and off status of almost any video component. It is used to provide status information to the IRF-6 System Interface Module or other RTI system interface devices. Since most televisions and video source equipment output a video signal or "blue" screen when they are on, the SPS-1 can sense true on and off status. When the attached component is powered on, the SPS-1 detects the vertical sync pulse present in the composite video signal and sends a logic signal to the System Interface Module.

The SPS-1 has a high impedance input and will not effect picture quality.

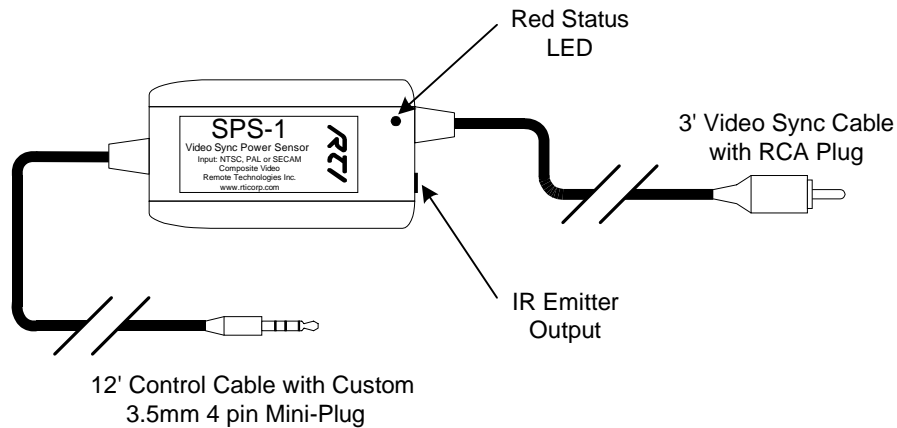

Placement

Place the SPS-1 body near the component it will be sensing. The unit can be placed in a concealed location since it needs no adjustment. If necessary, the Video Sync Cable can be extended up to 100 feet with RG-59 coax or similar wire.

Mount the SPS-1 body to a wall or other smooth, flat surface with the enclosed velcro.

IMPORTANT: Do not place the SPS-1 directly on a television set. TVs produce a large amount of electro-magnetic energy that may interfere with the operation of the SPS-1.

Installation

- 1) Attach an industry standard IR emitter on the IR sensor window of the component you wish to monitor, following the instructions that came with the emitter.
- 2) Connect the Video Sync Cable to the video source you are using to trigger the SPS-1.

Installation (con't.)

- 3) Insert the 3.5mm mini-plug from the IR emitter cable into the IR Emitter Output jack of the SPS-1.
- 4) Insert the 4 conductor mini-plug from the SPS-1 control cable into an output port of the IRF-6 System Interface Module or other RTI system interface device.
- 5) Test the operation of the SPS-1 by switching the component on. The red status light on the SPS-1 should be illuminated, indicating it is triggered and the component is on. If the status light is not illuminated, check the connections to verify everything is wired properly and the connections are good.
- 6) Use the programming software for your RTI System Controller to set the conditions you wish to use for that output.

